

# PZL P.11c

detail set for 1/32 IBG kit • sada detailů pro stavebnici 1/32 IBG

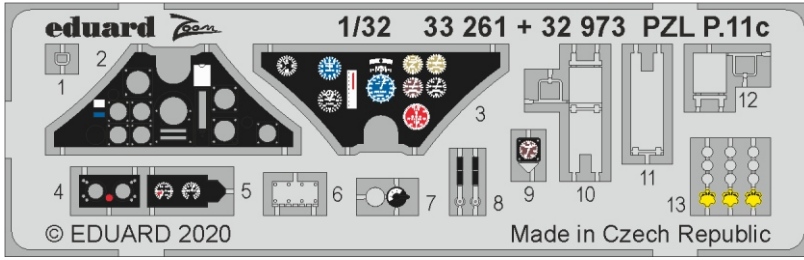

- APPLY EXPRESS MASK AND PAINT BEFORE GLUING  
POUŽIT EXPRESS MASK NABARVIT PŘED SLEPENÍM
  - SYMMETRICAL ASSEMBLY  
SYMETRICKÁ MONTÁŽ
  - REMOVE  
ODSTRANIT
  - GRIND  
OBROUSIT
  - DRILL HOLE  
VRTÁT OTVOR
  - BEND  
OHNOUT
  - OPTION  
VOLBA
  - REPLACE  
NAHRADIT
- 1** COLORED ETCHED PARTS  
LEPTANÉ BAREVNÉ DÍLY
- 1** ETCHED PARTS  
LEPTANÉ NEBAREVNÉ DÍLY
- 1** ORIGINAL KIT PARTS  
PŮVODNÍ DÍLY STAVEBNICE

ORIGINAL KIT PARTS PŮVODNÍ DÍLY STAVEBNICE      PHOTO-ETCHED PARTS LEPTANÉ DÍLY      PARTS TO BE REMOVED DÍLY K ODSTRANĚNÍ      FILL TMELIT

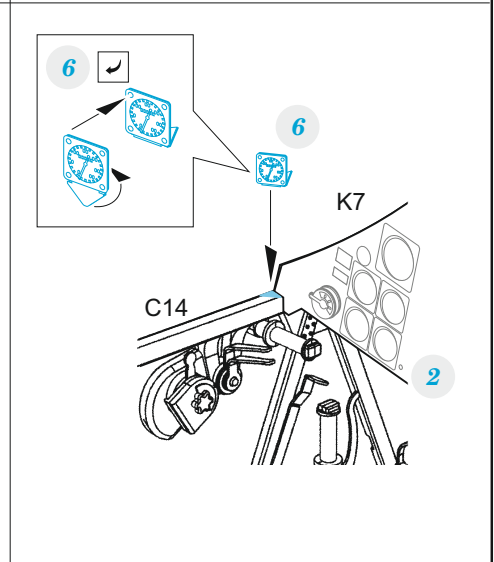
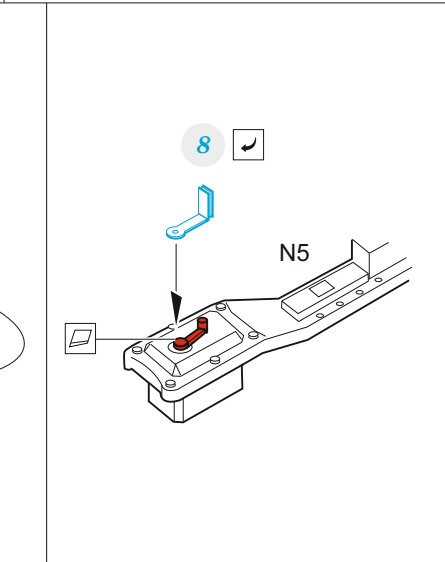
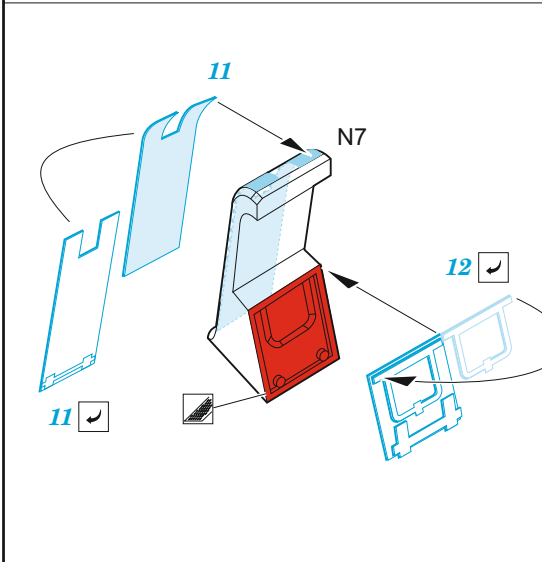
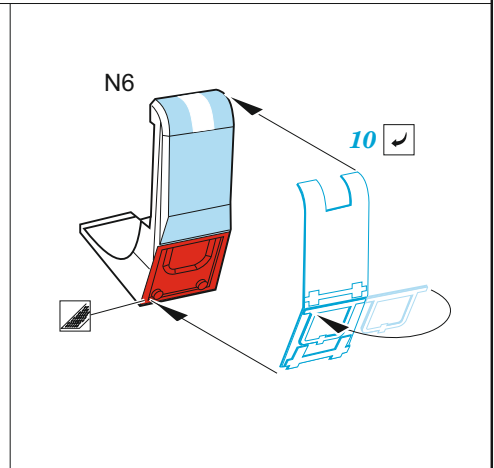
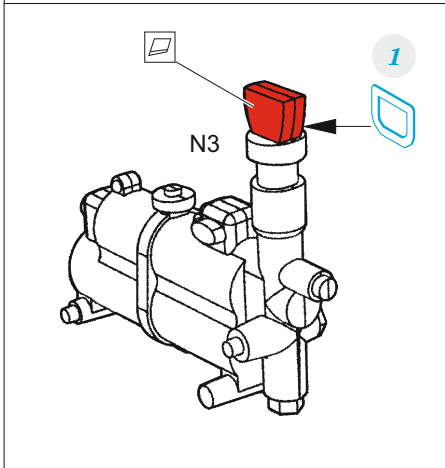
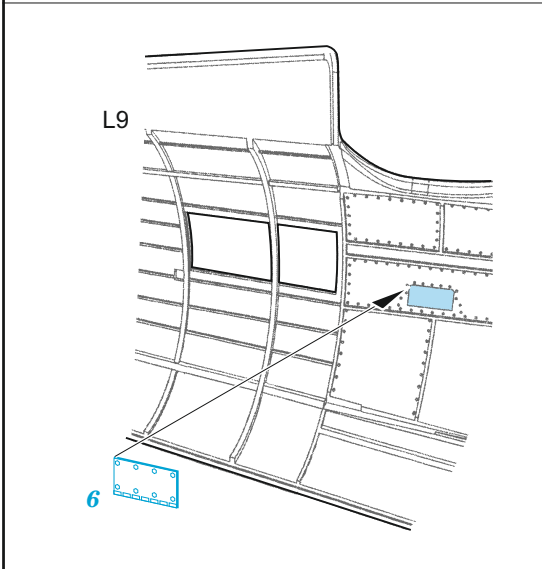
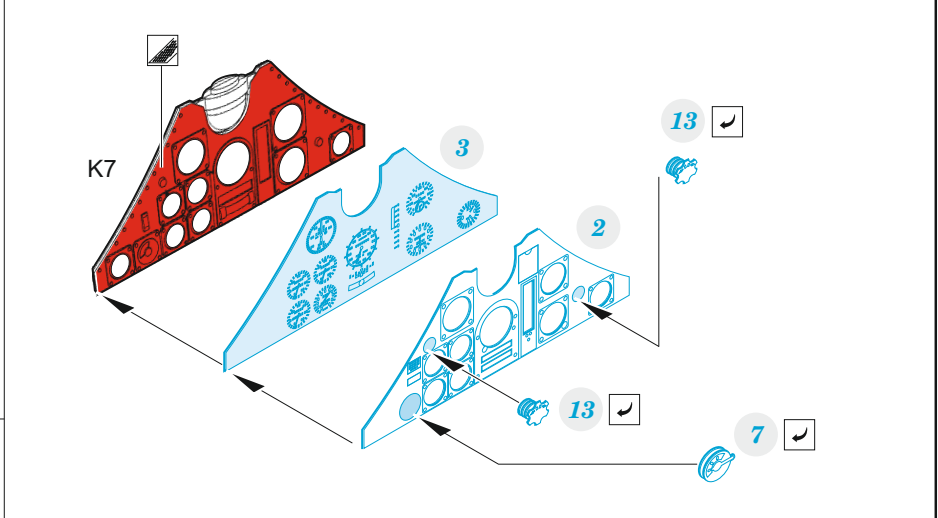
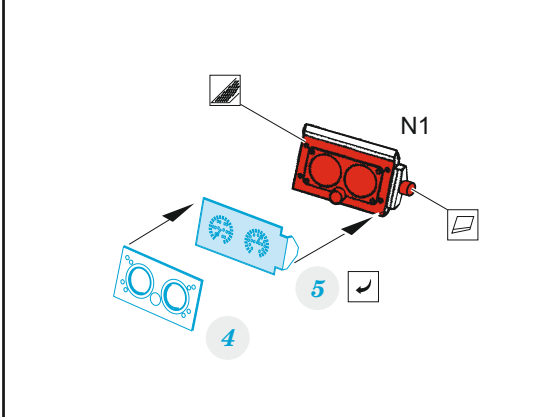

Related products: 33 262 PZL P.11c seatbelts STEEL 1/32

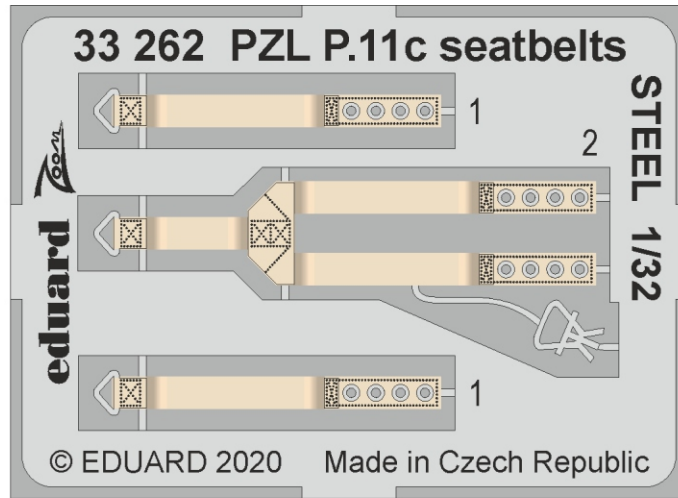

Related products: 32 973 PZL P.11c 1/32

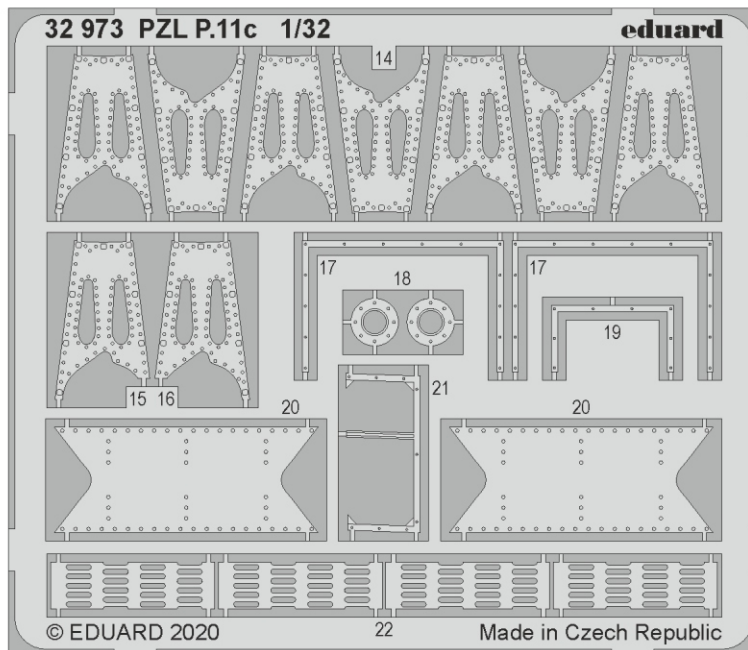

# PZL P.11c

detail set for 1/32 IBG kit • sada detailů pro stavebnici 1/32 IBG

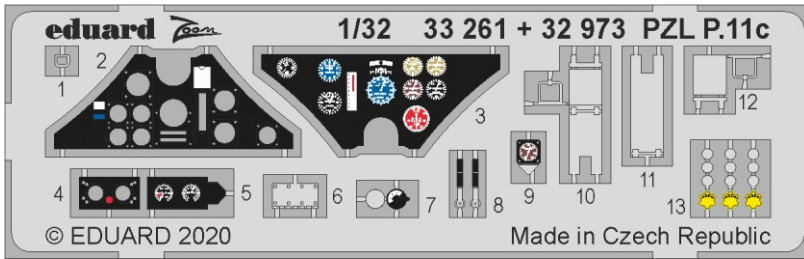

- APPLY EXPRESS MASK AND PAINT BEFORE GLUING  
POUŽIT EXPRESS MASK NABARVIT PŘED SLEPENÍM
  - SYMMETRICAL ASSEMBLY  
SYMETRICKÁ MONTÁŽ
  - REMOVE  
ODSTRANIT
  - GRIND  
OBROUSIT
  - DRILL HOLE  
VRTÁT OTVOR
  - BEND  
OHNOUT
  - OPTION  
VOLBA
  - REPLACE  
NAHRADIT
- 1** COLORED ETCHED PARTS  
LEPTANÉ BAREVNÉ DÍLY
- 1** ETCHED PARTS  
LEPTANÉ NEBAREVNÉ DÍLY
- 1** ORIGINAL KIT PARTS  
PŮVODNÍ DÍLY STAVEBNICE

ORIGINAL KIT PARTS PŮVODNÍ DÍLY STAVEBNICE      PHOTO-ETCHED PARTS LEPTANÉ DÍLY      PARTS TO BE REMOVED DÍLY K ODSTRANĚNÍ      FILL TMEELIT

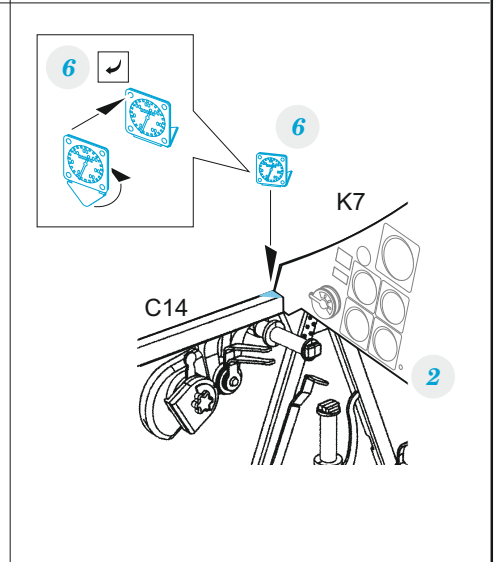
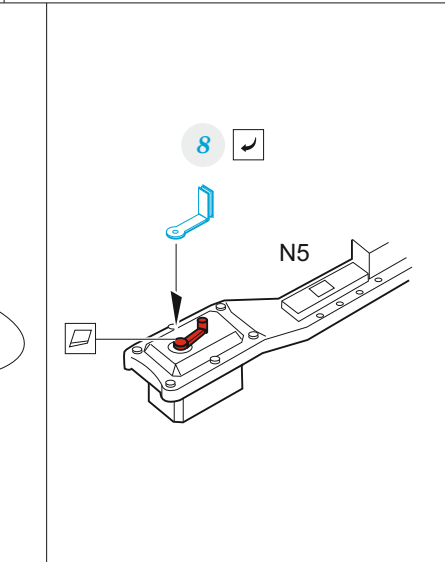
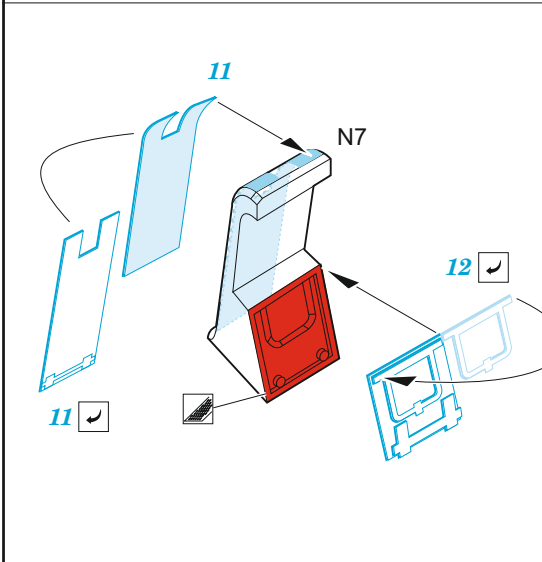
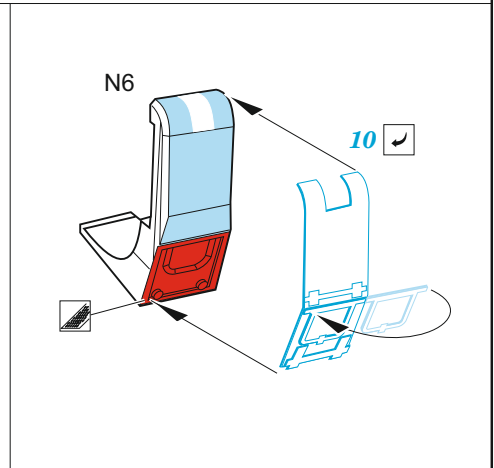
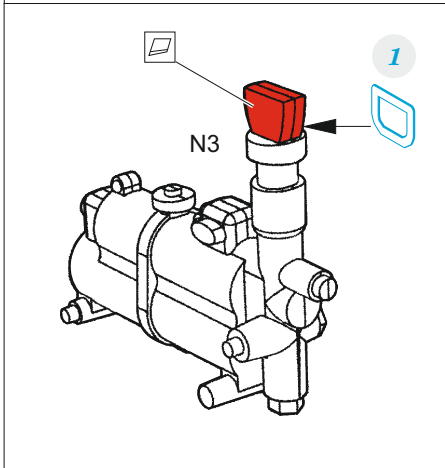
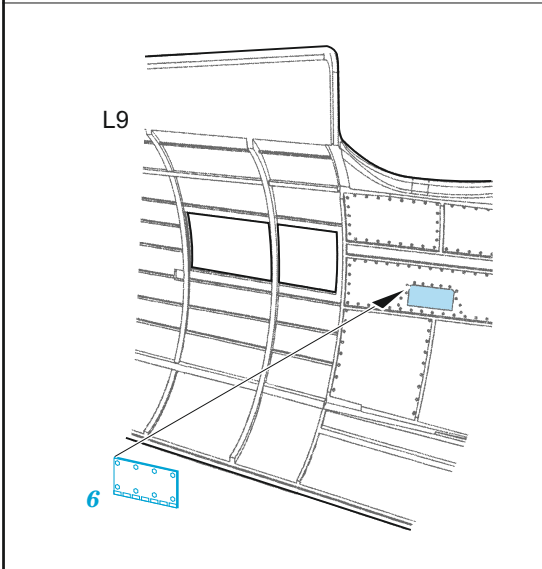
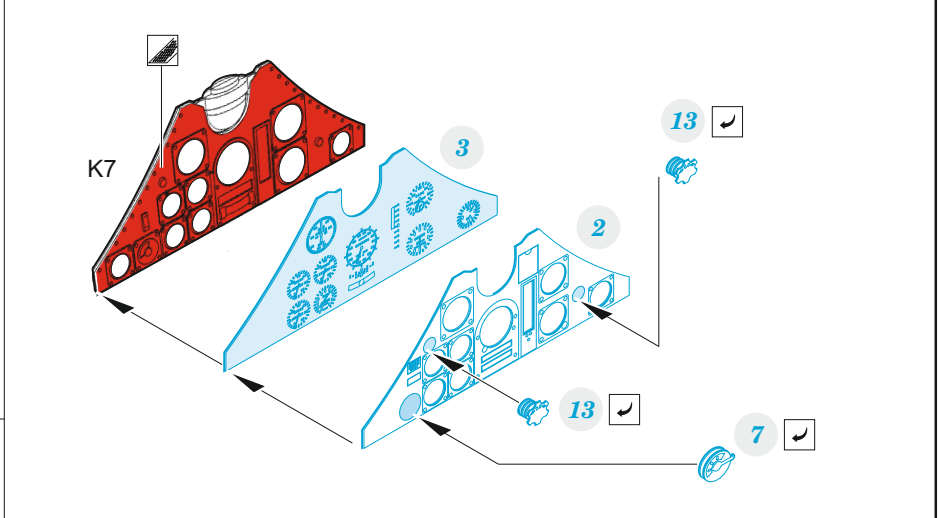
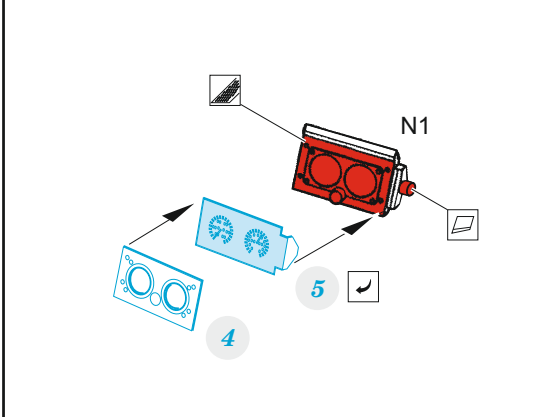

Related products: 33 262 PZL P.11c seatbelts STEEL 1/32

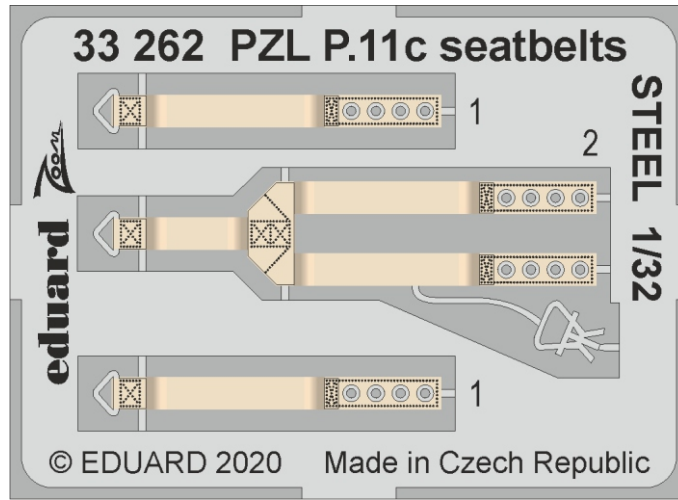

Related products: 32 973 PZL P.11c 1/32

